

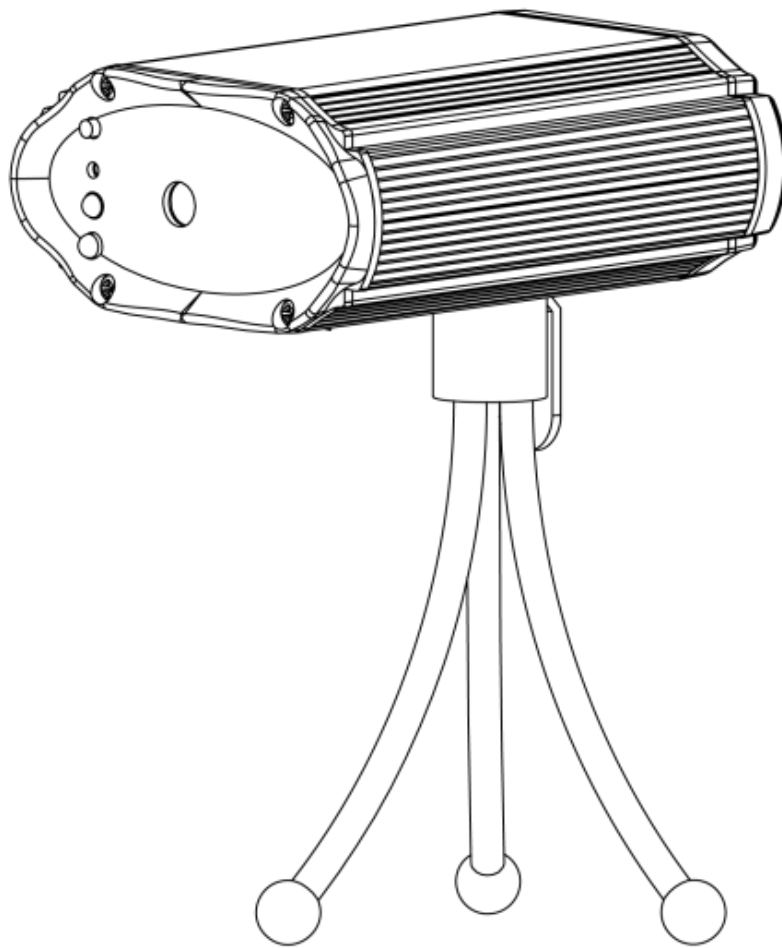

User Manual



LASER LIGHT
AVOID DIRECT EYE EXPOSURE
CLASS 3R LASER PRODUCT
CLASSIFIED PER EN/IEC 60825-1:2007
Complies with FDA performance standards
for laser products except for deviations
pursuant to Laser Notice No. 50, dated
June 24, 2007.



CHAUVET[®]
Value • Innovation • Performance

TABLE OF CONTENTS

Contact Information	2
1. Before You Begin	3
What Is Included	3
Unpacking Instructions	3
Claims	3
Manual Conventions	3
Icons	3
Safety Instructions	4
Non Interlocked Housing Warning	5
Laser Safety Notes	5
Laser Safety Label Reproduction	6
Laser Emission Data	7
Laser Compliance Statement	7
2. Introduction	8
Product Overview	8
3. Setup	9
AC Power	9
Mounting	9
Orientation	9
Rigging	9
Proper Usage	11
4. Operating Instructions	12
Manual Mode	12
Wireless Remote (IR)	12
5. Appendix	13
General Troubleshooting	13
Product Maintenance	14
Returns Procedure	15
Contact Information	15
6. Technical Specifications	16

Contact Information

World Headquarters

CHAUVET®

General Information

Address: 5200 NW 108th Avenue
Sunrise, FL 33351
Voice: (954) 929-1115
Fax: (954) 929-5560
Toll free: (800) 762-1084

Technical Support

Voice: (954) 929-1115 (Press 4)
Fax: (954) 756-8015

World Wide Web: www.chauvetlighting.com

United Kingdom & Ireland

CHAUVET® Europe Ltd.

General Information

Address: Unit 1C
Brookhill Road
Pinxton, Nottingham, UK
NG16 6NT
Voice: +44 (0)1773 511115
Fax: +44 (0)1773 511110
Email: uktech@chauvetlighting.com

World Wide Web: www.chauvetlighting.co.uk

1. BEFORE YOU BEGIN

What Is Included

- 1 x MiN™ Laser RBX
- 1 x Flexible tripod
- 1 x Adjustable stand
- 1 x Wireless remote
- 1 x Power supply
- 1 x Clamp adaptor
- 1 x Warranty card
- 1 x User manual

Unpacking Instructions

Immediately upon receipt, carefully unpack this product and check the container to make sure you have received all the parts indicated above in good condition.

Claims

If the container or the material inside the container (this product and any other accessory included) appears damaged from shipping, or shows signs of mishandling, notify the carrier immediately, not CHAUVET®, upon receipt of the damaged merchandise. Failure to do so in a timely manner may invalidate your claim with the carrier. In addition, retain the container and all the packing material for inspection.

For other issues such as missing components or parts, damage not related to shipping, or concealed damage, file a claim with CHAUVET® within seven (7) days of receiving the merchandise.



Manual Conventions

CHAUVET® manuals use the following conventions to differentiate certain types of information from the regular text.

Convention	MEANING
<Menu>	A key to be pressed on the product's control panel
1~512	A range of values
50/60	A set of values of which only one can be chosen
Settings	A menu option not to be modified (for example, showing the operating mode/current status)
MENU > Settings	A sequence of menu options to be followed
ON	A value to be entered or selected

Icons

This manual uses the following icons to indicate information that requires special attention on the part of the user.

Icons	MEANING
	This paragraph contains critical installation, configuration or operation information. Failure to comply with this information may render the product partially or completely inoperative, cause damage to the product or cause harm to the user.
	This paragraph contains important installation or configuration information. Failure to comply with this information may prevent the product from functioning correctly.
	This paragraph reminds you of useful, although not critical, information.

Safety Instructions



Please read the following notes carefully because they include important safety information about the installation, usage, and maintenance of this product.

- Keep this User Manual for future consultation. If you sell this product to another user, be sure that they also receive this document.
 - Always make sure that the voltage of the outlet to which you are connecting this product is within the range stated on the decal or rear panel of the product.
 - This product is for indoor use only! To prevent risk of fire or shock, do not expose this product to rain or moisture.
 - Make sure there are no flammable materials close to the unit while operating.
 - Always install this product in a location with adequate ventilation, at least 20 in (50 cm) from adjacent surfaces. Be sure that no ventilation slots are blocked.
 - Always disconnect this product from the power source before cleaning it or replacing fuse.
 - Make sure to replace the fuse with another of the same type and rating.
 - If mounting it overhead, always secure this product to a fastening device using a safety chain.
 - The maximum ambient temperature (T_a) is 104° F (40° C). Do not operate this product at higher temperatures.
 - In the event of a serious operating problem, stop using the unit immediately. Never try to repair the unit. Repairs carried out by unskilled people can lead to damage or malfunction. Please contact the nearest authorized technical assistance center.
 - Never connect this product to a dimmer pack.
 - Make sure the power cord is not crimped or damaged.
 - Never disconnect the power cord by pulling or tugging on the cord.
 - Never carry a product from the power cord or any moving part. Always use the hanging/mounting bracket or the handles.
 - Always avoid direct eye exposure to the light source when this product is on.
 - Lasers can be hazardous and have unique safety considerations. Permanent eye injury and blindness is possible if lasers are used incorrectly. Pay close attention to each safety REMARK and WARNING statement in this user manual. Read all instructions carefully BEFORE operating this device.
-
- **Avoid direct eye contact with laser light. Never intentionally expose your eyes or others to direct laser light.**
 - **This laser product can potentially cause instant eye injury or blindness if laser light directly strikes the eyes.**
 - **It is illegal and dangerous to shine this laser into audience areas, where the audience or other personnel could get direct laser beams or bright reflections into their eyes.**
- 
- **It is a US Federal offense to shine any laser at aircraft.**
 - **Use of controls or adjustments or performance of procedures other than those specified herein may result in hazardous radiation exposure.**
 - **There are no user serviceable parts inside the unit. Do not open the housing or attempt any repairs yourself. In the unlikely event your unit may require service, please contact the dealer nearest to you.**
 - **Avoid direct eye contact with laser light. Never intentionally expose your eyes or others to direct laser light.**

Non Interlocked Housing Warning

- This unit contains high power laser devices internally.
- Do not open the laser housing, due to potential exposure to unsafe levels of laser radiation.
- The laser power levels, accessible if the unit is opened, can cause instant blindness, skin burns, and fires.

Laser Safety Notes



STOP AND READ ALL THE LASER SAFETY NOTES BELOW

Laser Light is different from any other light sources with which you may be familiar. The light from this product can potentially cause eye injury if not set up and used properly. Laser light is thousands of times more concentrated than light from any other kind of light source. This concentration of light can cause instant eye injuries, primarily by burning the retina (the light sensitive portion at the back of the eye). Even if you cannot feel “heat” from a laser beam, it can still potentially injure or blind you or your audience. Even very small amounts of laser light are potentially hazardous even at long distances. Laser eye injuries can happen quicker than you can blink.

It is incorrect to think that because these laser entertainment products split the laser into hundreds of beams that the laser beam is scanned out in high speed, that an individual laser beam is safe for eye exposure. This laser product uses dozens of milliwatts of laser power (Class 3B levels internally) before it splits into multiple beams (Class 3R levels). Many of the individual beams are potentially hazardous to the eyes.

It is also incorrect to assume that because the laser light is moving, it is safe. This is not true. Nor, do the laser beams always move. Since eye injuries can occur instantly, it is critical to prevent the possibility of any direct eye exposure. In the laser safety regulation, it is not legal to aim Class 3R lasers in areas which people can get exposed. This is true even if it is aimed below people’s faces, such as on a dance floor.

- Do not operate the laser without first reading and understanding all safety and technical data in this manual.
- Always set up and install all laser effects so that all laser light is at least 3 meters (9.8 feet) above the floor on which people can stand. See “Proper Usage” section later in this manual.
- After set up, and prior to public use, test laser to ensure proper function. Do not use if any defect is detected. Do not use if laser emits only one or two laser beams rather than dozens/hundreds, as this could indicate damage to the diffraction grating optic, and could allow emission of higher laser levels above Class 3R.
- Do not point lasers at people or animals.
- Never look into the laser aperture or laser beams.
- Do not point lasers in areas in which people can potentially get exposed, such as uncontrolled balconies, etc.
- Do not point lasers at highly reflective surfaces, such as windows, mirrors and shiny metal. Even laser reflections can be hazardous.
- Never point a laser at aircraft, this is a federal offense.
- Never point un-terminated laser beams into the sky.
- Do not expose the output optic (aperture) to cleaning chemicals.
- Do not use laser if the laser appears to be emitting only one or two beams.
- Do not use the laser if the housing is damaged, open, or if the optics appear damaged in any way.
- Never open the laser housing. The high laser power levels inside of the protective housing can start fires, burn skin and will cause instant eye injury.
- Never leave this device running unattended.
- The operation of a class 3R laser show is only allowed if the show is controlled by a skilled and well-trained operator, familiar with the data included in this manual.
- The legal requirements for using laser entertainment products vary from country to country. The user is responsible for the legal requirements at the location/country of use.
- Always use appropriate lighting safety cables when hanging lights and effects overhead.



Laser Safety Label Reproduction

<p>CHAUVET Lighting 5200 NW 108th Avenue Sunrise, FL 33351</p>	<p>LASER LIGHT AVOID DIRECT EYE EXPOSURE CLASS 3R LASER PRODUCT <5 mW, 450 nm & 650 nm, 100 mSec - CW CLASSIFIED PER EN/IEC 60825-1:2007</p>	<p>NAME: MiN™ Laser RBX ITEM CODE: 10060477 VOLTAGE: 12 VDC, 1 A CURRENT: 0.1A @ 120 V POWER: 8 W @ 120 V POWER LINKING MAX: N/A ORIGIN: MADE IN P.R.C.</p>
<p>Complies with FDA performance standards for laser products except for deviations pursuant to Laser Notice No. 50, dated June 24, 2007</p>		<p>RoHS  </p> <p>MANUFACTURING DATE:</p>

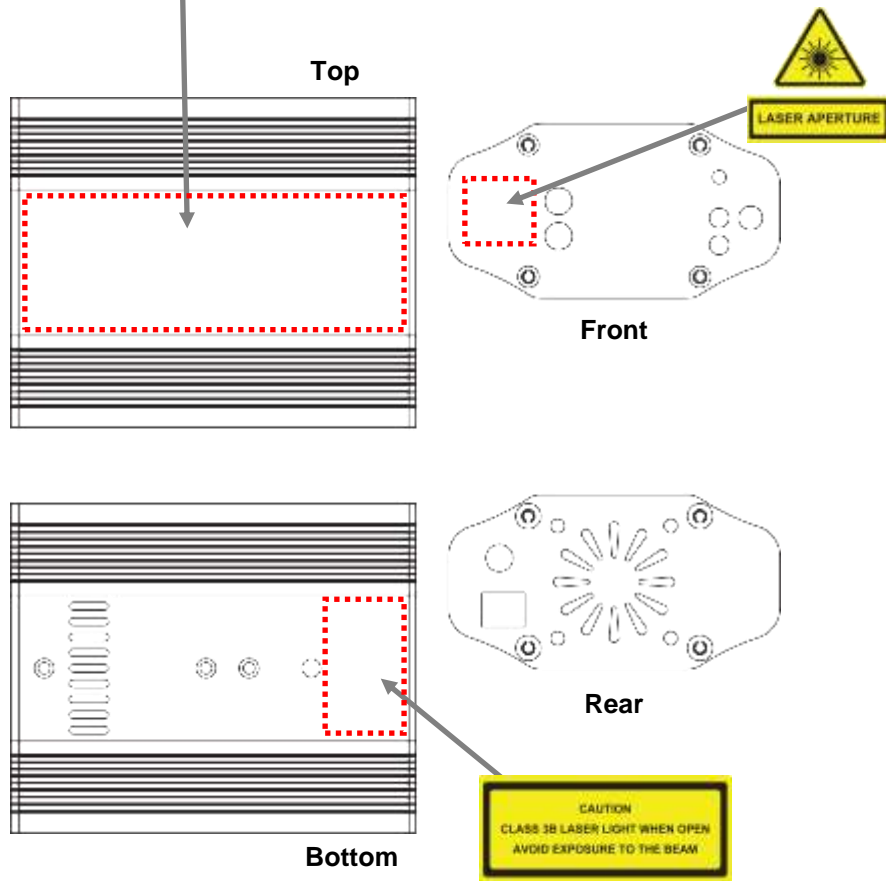



LASER EXPOSURE



Laser light - Avoid direct eye contact!

Further guidelines and safety programs for safe use of lasers can be found in the ANSI Z136.1 Standard "For Safe Use of Lasers", available from the Laser Institute of America: www.laserinstitute.org. Many local governments, corporations, agencies, military and others, require all lasers to be used under the guidelines of ANSI Z136.1. Laser Display guidance can be obtained via the International Laser Display Association: www.laserist.org.

Laser Emission Data

Laser Classification	Class 3R
Blue Laser Medium	LD InGaN, 450 nm
Red Laser Medium	LD GaAlAs, 650 nm
Beam Diameter	<5mm at aperture
Pulse Data	All pulses < 4 Hz (>0.25 sec)
Divergence (each beam)	<2 mrad
Divergence (total light)	<160 degrees
Laser Power of Each Beam from Aperture*	<5 mW

**As measured under IEC measurement conditions for classification.*

Laser Compliance Statement



This laser product complies with EN/IEC 60825-1 Ed 2, 2007-03, and US FDA/CDRH FLPPS via the terms of Laser Notice No. 50 dated June 24, 2007. This laser device is classified 3R. (Class 3R is the international equivalent of US Class IIIa). No maintenance is required to keep this product in compliance with laser performance standards.

2. INTRODUCTION

Product Overview

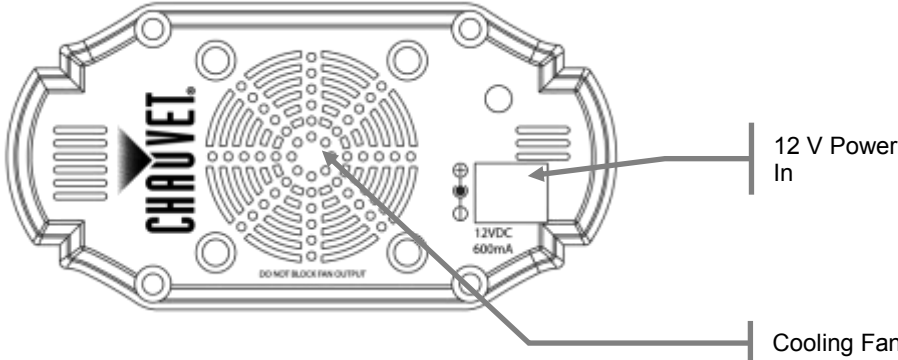
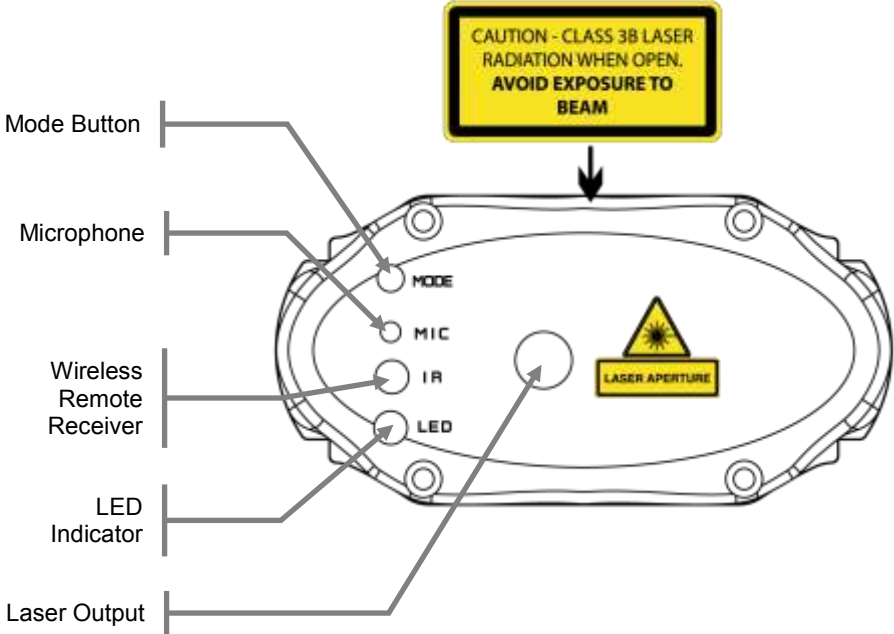

3. SETUP

AC Power



This product includes an external power supply which is auto-ranging and runs on 100~240 VAC, 50/60 Hz power. Only use the included power supply! To obtain a replacement power supply, contact Chauvet®.

To determine the power requirements for a particular product, see the label affixed to the back plate of the product or refer to the product's specifications chart. A product's listed current rating indicates its average current draw under normal conditions.



Always connect the product to a switched circuit. Never connect the product to a rheostat (variable resistor) or dimmer circuit, even if the rheostat or dimmer channel is used only as a 0 to 100% switch.

Mounting

Orientation

The MiN™ Laser RBX may be mounted in any position provided there is adequate room for ventilation.

Rigging

Be sure that the structure can support the weight of the product. Please see the "Technical Specifications" section of this manual for a detailed weight listing. Mount the product securely. Do this with a screw, nut and bolt, or a hanging clamp. When rigging, consider routine maintenance. Please see the following notes on installation.

- When aiming the products, you may use the bracket adjustment knob(s). Loosen the knob(s), adjust to the desired angle, and then tighten the knob(s) by turning clockwise. Do not use tools for this step, as it may cause damage.
- Use the floor stand to support the product in a sitting position.

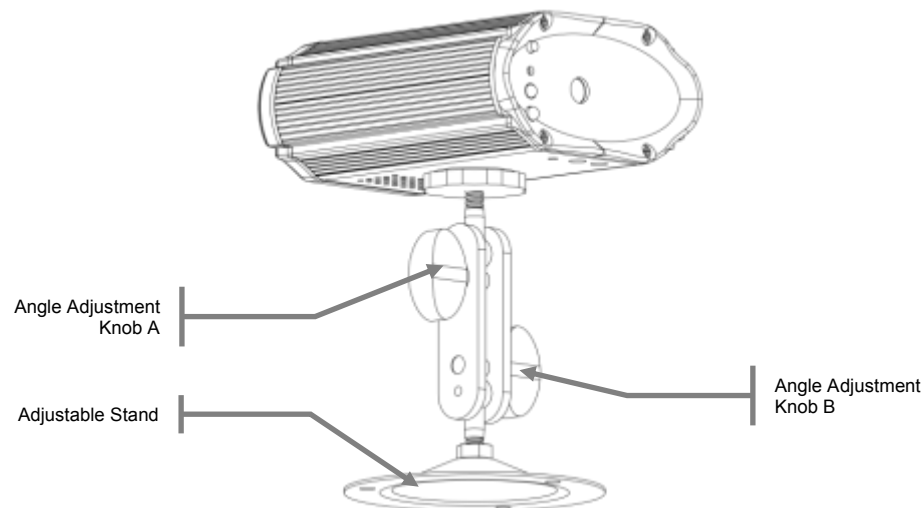

Continued on next page

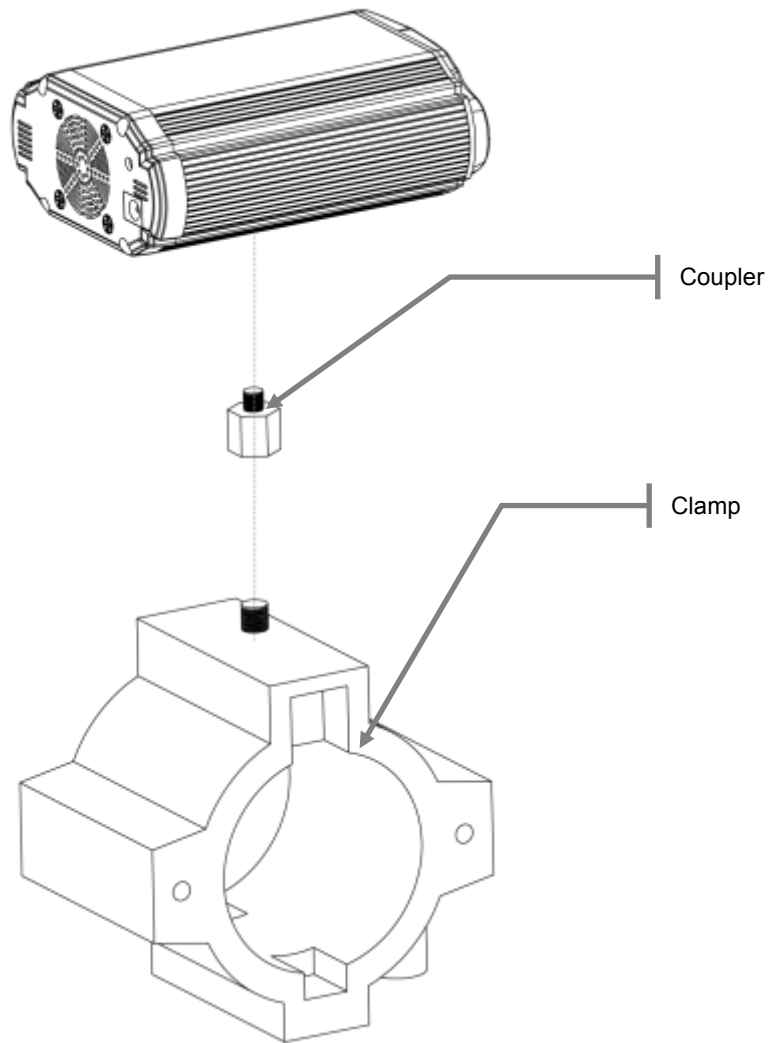
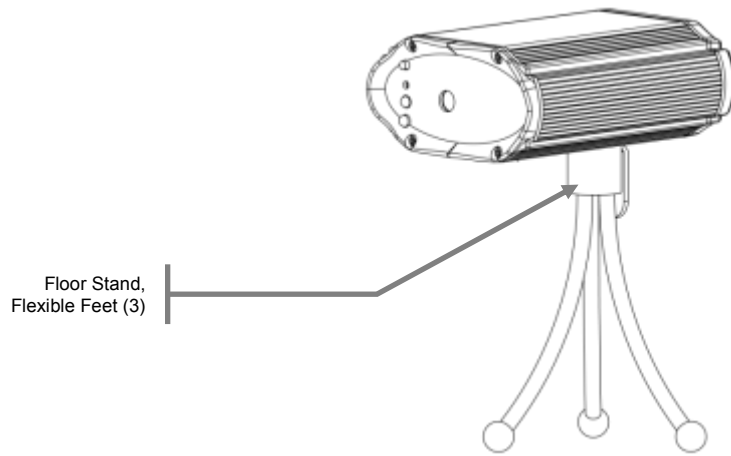

Proper Usage

This product is for overhead mounting only. For safety purposes, CHAUVET® recommends mounting your lighting effect products on steady elevated platforms or sturdy overhead supports using suitable hanging clamps. In all cases, you must use safety cables. You can obtain appropriate mounting hardware from your lighting vendor.

International laser safety regulations require that laser products must be operated in the fashion illustrated below, with a minimum of 3 meters (9.8 ft) of vertical separation between the floor and the lowest laser light vertically. Additionally, 3 meters of horizontal separation is required between laser light and audience or other public spaces.

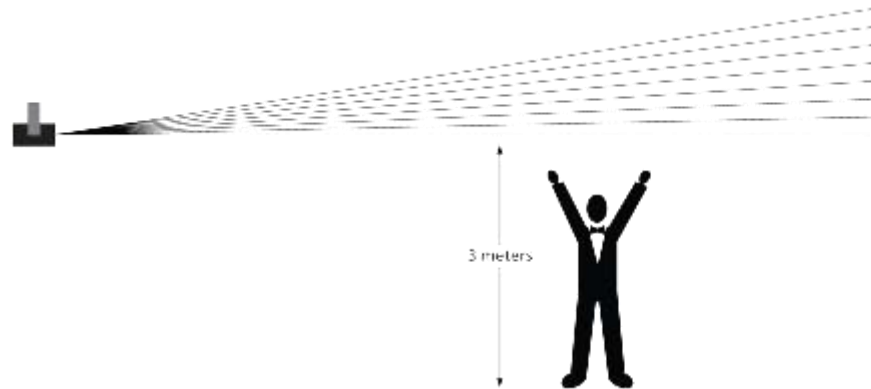

CAUTION - USE OF CONTROLS OR ADJUSTMENTS OR PERFORMANCE OF PROCEDURES OTHER THAN THOSE SPECIFIED HEREIN MAY RESULT IN HAZARDOUS RADIATION EXPOSURE

4. OPERATING INSTRUCTIONS

Manual Mode

Access the four different operating modes available in this product by using the **<MODE>** button on the front panel. Pressing and holding the **<MODE>** button for 2.5 seconds will turn the product on or off.

Press **<MODE>** to cycle through the modes. Please see a description of each mode below.

Mode	Description
1	Sound-active A
2	Sound-active B
3	Automatic A (fast effects)
4	Automatic B (slow effects)



The LED indicator on the front of the product will be blue when a sound-active mode is selected.

The LED indicator on the front of the product will be red when an automatic mode is selected.

Wireless Remote (IR)

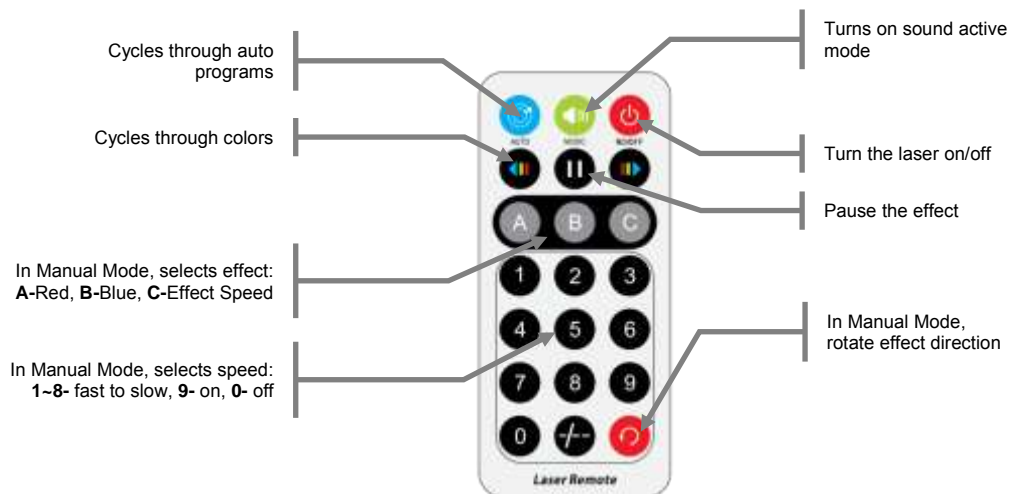

*The wireless Remote (IR) will immediately override the **<MODE>** button. No additional settings are required!*

5. APPENDIX

General Troubleshooting

SYMPTOM	POSSIBLE CAUSE(S)	POSSIBLE ACTION(S)
Breaker/Fuse keeps blowing	<ul style="list-style-type: none">• Excessive circuit load• Short circuit along the power wires	<ul style="list-style-type: none">• Check total load placed on the electrical circuit.• Check for a short in the electrical wiring (internal and/or external).
Device does not power up	<ul style="list-style-type: none">• No power• Loose power cord	<ul style="list-style-type: none">• Check for power on Mains.• Check power cord
Product is not responding to DMX	<ul style="list-style-type: none">• Wrong DMX addressing• Damaged DMX cables• Wrong polarity settings on the controller• Loose DMX cables• Faulty DMX interface• Faulty Main PCB	<ul style="list-style-type: none">• Check Control Panel and unit addressing• Check DMX cables• Check polarity switch settings on the controller• Check cable connections• Replace DMX input• Replace Main PCB



If you still have a problem after trying the above solutions, please contact CHAUVET® Technical Support.

Product Maintenance

Dust build up reduces light output performance and can cause overheating. This can lead to reduction of the light source's life and mechanical wear. To maintain optimum performance and minimize wear, you should clean your lighting products at least twice a month. However, be aware that usage and environmental conditions could be contributing factors to increase the cleaning frequency.

To clean this lighting product, follow the instructions below:

1. Unplug the product from power.
2. Wait until the product is cold.
3. Use a vacuum (or dry compressed air) and a soft brush to remove dust collected on the external surface and fan vents.
4. Clean the glass panel (laser aperture) with a mild solution of glass cleaner or isopropyl alcohol.
5. Apply the solution directly to a soft, lint-free cotton cloth or a lens cleaning tissue, and drag any dirt or grime to the outside of the glass.
6. Gently polish the glass surface until it is free of haze and lint.



Always dry the glass surface carefully after cleaning them.



**Do not spin the fan using compressed air because you could damage it.
DO NOT open this product for cleaning or servicing.**

Returns Procedure

The user must send the merchandise prepaid, in the original box, and with its original packing and accessories. CHAUVET® will not issue call tags.

Call CHAUVET® and request a Return Merchandise Authorization (RMA) number before shipping the product. Be prepared to provide the model number, serial number, and a brief description of the cause for the return.

The user must clearly label the package with a Return Merchandise Authorization (RMA) number. CHAUVET® will refuse any product returned without an RMA number.



DO NOT write the RMA number directly on the box. Instead, write it on a properly affixed label.

Once you have received the RMA number, please include the following information on a piece of paper inside the box:

- Your name
- Your address
- Your phone number
- The RMA number
- A brief description of the problem

Be sure to pack the product properly. Any shipping damage resulting from inadequate packaging will be the customer's responsibility. As a suggestion, proper UPS packing or double-boxing is always a safe method to use.



CHAUVET® reserves the right to use its own discretion to repair or replace returned product(s).

Contact Information

World Headquarters

CHAUVET®

General Information

Address: 5200 NW 108th Avenue
Sunrise, FL 33351
Voice: (954) 929-1115
Fax: (954) 929-5560
Toll free: (800) 762-1084

Technical Support

Voice: (954) 929-1115 (Press 4)
Fax: (954) 756-8015
Email: tech@chauvetlighting.com

World Wide Web

www.chauvetlighting.com

United Kingdom & Ireland

CHAUVET® Europe Ltd.

General Information

Address: Unit 1C
Brookhill Road Industrial Estate
Pinxton, Nottingham, UK
NG16 6NT
Voice: +44 (0)1773 511115
Fax: +44 (0)1773 511110

Technical Support

Email: uktech@chauvetlighting.com

World Wide Web

www.chauvetlighting.co.uk

6. TECHNICAL SPECIFICATIONS

Dimensions and Weight

Length	Width	Height	Weight
4.3 in (111 mm)	3.3 in (85 mm)	1.8 in (45 mm)	0.7 lbs (0.3 kg)

Note: Dimensions in inches rounded to the nearest decimal digit

Power

Input Voltage	Range	Voltage Selection
12 VDC 600 mA	100~240 V, 50/60 Hz	Auto-ranging



Parameter	120 V, 60 Hz	230 V, 50 Hz
Energy consumption	8 W	10 W
Operating current (units)	0.1 A	0.1 A

Power I/O	Input	Output
Connectors	External Supply	N/A

Light Source

MiN Laser RBX

Type	Power	Wavelength
Laser (blue)	80 mW	450 nm
Laser (red)	100 mW	650 nm

Photo Optic

Parameter	Value
Coverage angle	100°

Thermal

Maximum External Temp.	Cooling System
104° F (40° C)	Fan cooled

Ordering

Product Name	Item Code	Item Number
MiN™ Laser RBX	10060477	MINLASERRBX